

FLUSH MOUNT TEST TAP

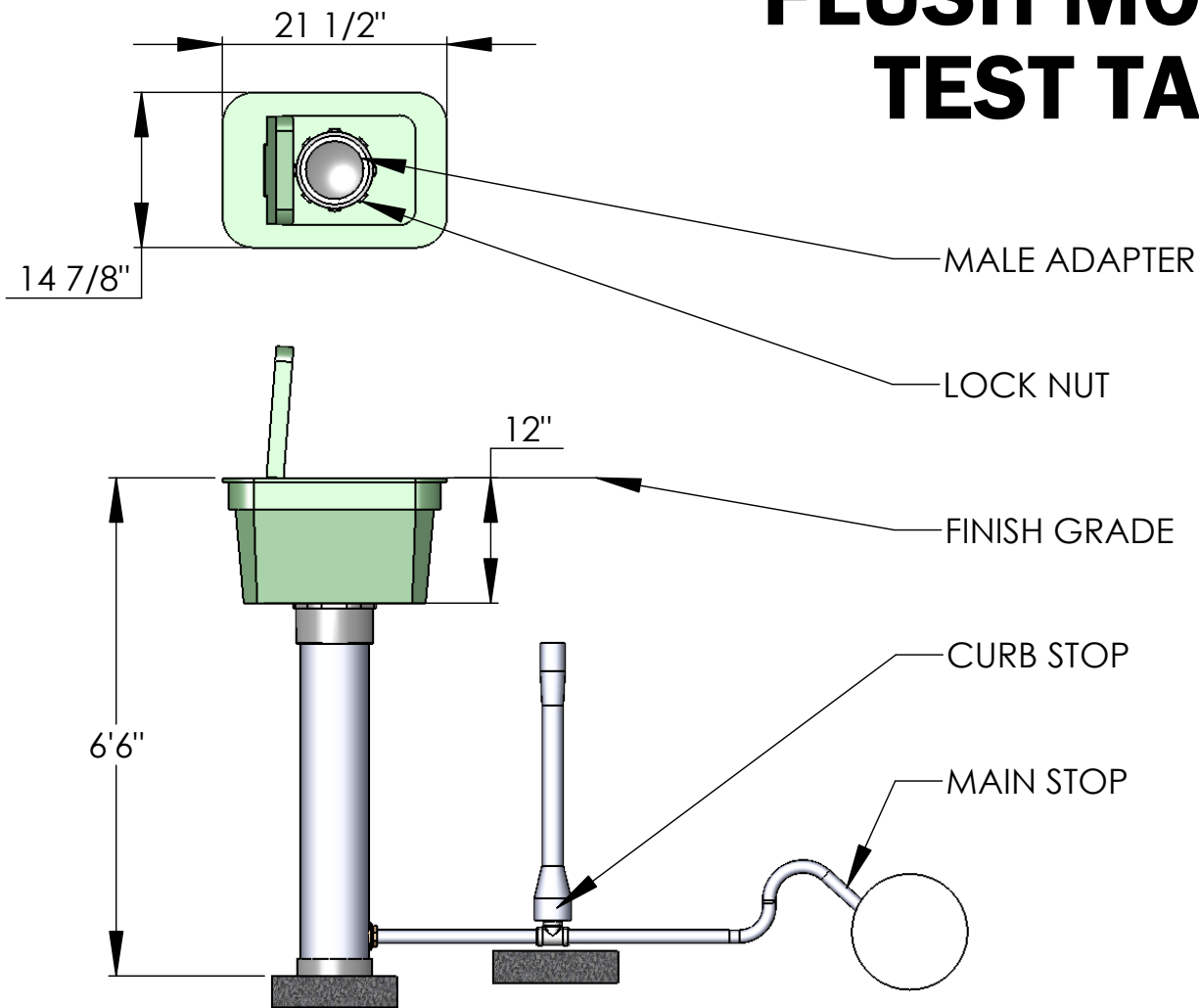

- Test Tap internals to be interchangeable (sampling, flushing, etc)
- The enclosure shall be made from pvc pipe with a lockable access box to be installed flush with ground
- After the water is turned off at the curbstop, all working parts shall be removable without digging.
- Stations will be equipped with a 1" FIP inlet for the connection to the watermain.
- Standard Flush Mount Test Tap is designed for a 1.8m (6 feet) bury (alternative length available)

Typical Installation from Watermain to Flush Mount Test Tap

3/4" Mainstop, 3/4" domestic pipe to a 3/4" curbstop, 3/4" service pipe, 3/4" compression x 1" MIP fitting to Pitless

Notes:

1. The Flush Mount Test Tap should rest on a concrete slab. 30cm x 30cm patio slab is acceptable.
2. The curb stop should rest on a concrete slab. Small patio slab is acceptable.
3. If no-lead fittings (mainstop, curbstop etc) are used to connect the Flush Mount Test Tap to the watermain, this would provide complete no-lead sample point.
4. It is recommended to use pipe lube between male adapter and the 6" pipe rather than glue. This allows movement for frost heaving.

TITLE:
FLUSH MOUNT TEST TAP

DWG NO.
DR-12

A4

SCALE:1:18

SHEET 1 OF 1